

Mixed I/O Module

for the MOSCAD RTU

The Mixed Input/Output module is an accessory to the MOSCAD RTU family that permits up to eight dry-contact closures, from switches or relays in other on-site equipment, to be connected to the RTU plus up to two 4-20 ma analog inputs, from on-site tank level or flow-rate sensors, to be connected to the RTU. It also provides four relay outputs that may control on-site electrical devices.

FEATURES/BENEFITS

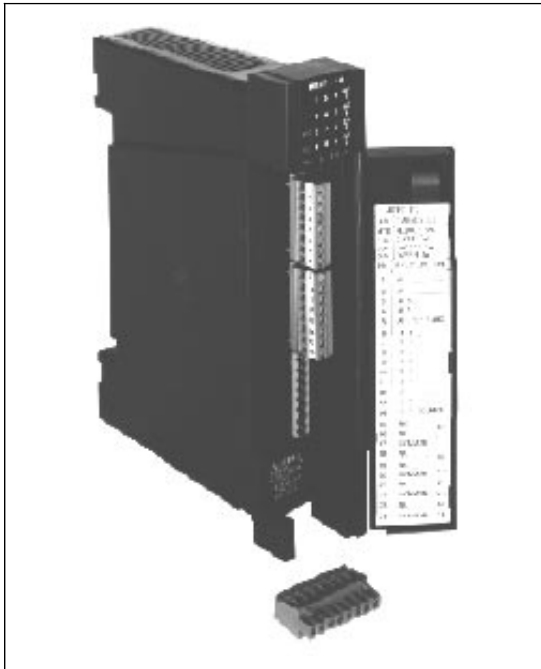

Digital Data Input

Under the control of the defined Application Program, the CPU module in the RTU will read the current instantaneous status of one or more of the eight status inputs or two analog inputs. It moves that data from the module into the CPU module via the motherboard.

◆ *This data may then be used by the Application Program. Similarly, the CPU module will move data associated with the four relays into the module and may control the state of those relays.*

Low-Speed Counter Inputs

Each of the eight digital inputs may be used as low-speed counter inputs if desired. The totalizing must be done within the CPU module under Application control. The Application must read the associated input(s) in a timely manner to assure not missing any input event.

◆ *Any number of counter inputs are easily obtained.*

Time-Tagging

Any of the eight digital inputs may be defined to tag the time of the input event with one millisecond accuracy.

◆ *This time may then be read and used in sequence-of-event actions, etc. or used later for historical reports*

Relay Outputs

Different modules are available with four electrically-energized (EE) relays or with three magnetically-latched (ML) plus one electrically-energized relays.

◆ *The all-EE relay version should be used when it is mandatory that the relays open when power is lost or control otherwise disrupted. The 3ML-1EE relay version should be used when prolonged operation from the backup battery power source is expected.*

Optical Isolation

All digital and analog inputs are protected by optical isolators on the module.

◆ *Surge Withstand Capability (SWC) conformance is assured for the safety of the equipment and technicians.*

Packaging

The module is packaged in a plastic housing that plugs and locks into the motherboard. Wire connections (up to 14 ga. wire) are made to removable connectors on the face of the module. No jumpers, calibration pots, etc. are located on the module (any calibration is done electronically via software from the ToolBox program.)

◆ *Modularity allows the MOSCAD RTU to be easily expanded as system wants and needs change and makes field module replacement quick and easy.*



MOTOROLA

Specifications

Order	Plant Installed: Magnetically-latched—V245; Electrically-energized—V436 Field Installed: Magnetically-latched—FRN1484; Electrically-energized—FRN1490
Digital Inputs	8; may be counters (50 Hz or less)
DI Source Resistance	Close: < 4 kohm Open: >70 kohm
Digital Input Isolation Digital Input Protection	On-board DC/DC converter; optical isolation 2.5 kV oscillatory SWC per ANSI C37.90.1-1989
Analog Inputs: Input Resistance Resolution Overall Accuracy	Two; 4-20 ma only 226 ohm 10 bits (including sign) over full ± 20 ma range 0.5%
Relay Outputs Contact Rating Output Protection	4 relays, either all Electrically-energized (EE) or 3 Magnetically-latched and 1 EE 60W or 125 VA, not to exceed 2 amp and 250 volts 1 kV between contacts, 1.5 kV between contact & coil per ANSI C37.90.1-1989
Diagnostic	20 LEDs: 16 for outputs, 1 each for Module Fail and No Clock
Power	5 Vdc: 5 ma (ML), 25 ma (EE) 12 Vdc: ML: 5 ma (45 ma with LEDs on) EE: 260 ma (300 ma with LEDs on)
Environment	Humidity: 0 to 90% @ +50°C Temperature: -30 to +60°C

Typical Digital Input Circuit

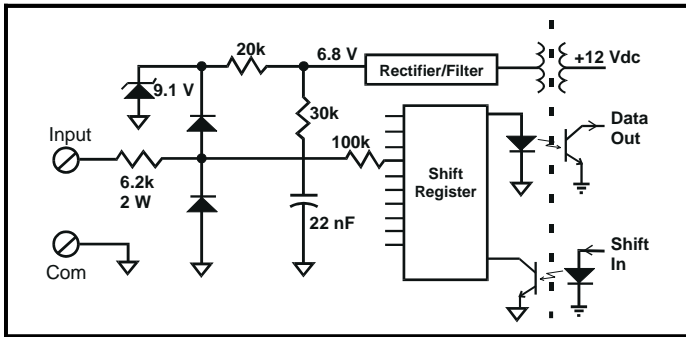

Typical Analog Input Circuit

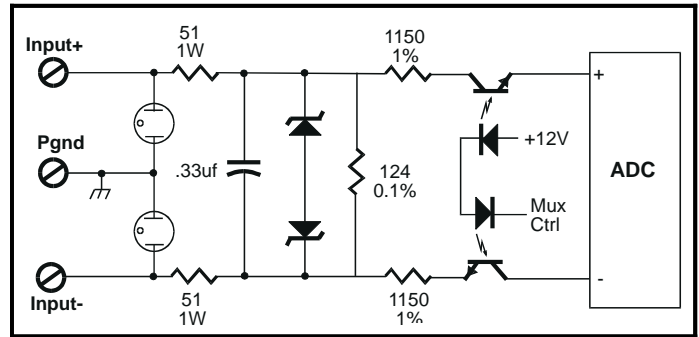

Typical Relay Output Circuit

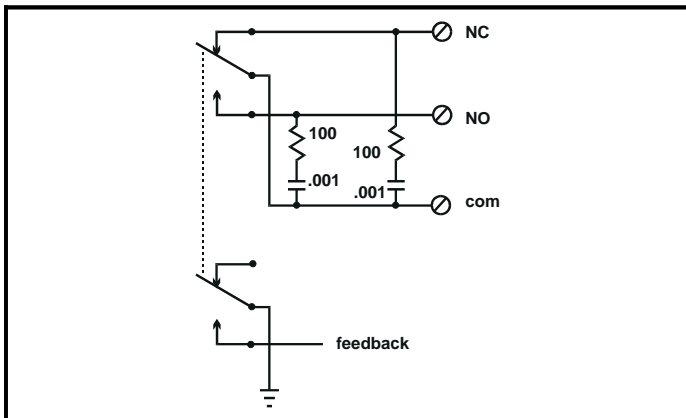

Connections Chart

Term	Function	Term	Function
1	Analog Input 1 (+)	13	Digital Input 8
2	Analog Input 1 (-)	14	DI common
3	Analog Input 2 (+)	15	K1 NC (EE or ML)
4	Analog Input 2 (-)	16	K1 NO
5	P. Gnd	17	k1 common
6	Digital Input 1	18	K2 NC (EE or ML)
7	Digital Input 2	19	K2 NO
8	Digital Input 3	20	K2 common
9	Digital Input 4	21	K3 NO (EE or ML)
10	Digital Input 5	22	K3 common
11	Digital Input 6	23	K4 NO (EE only)
12	Digital Input 7	24	K4 common